



**Specifications:**

20W, MR-16 Metal Halide Spot with integral ballast for 120 volt flexible track system.

**Features**

1. **Threaded Coupling Cap:** made of die cast aluminum; locks coupler onto track.
2. **Hinged Extrusion Coupler:** made of die cast aluminum; connects fixture to track.
3. **Swivel:** 358 Degree rotation for horizontal adjustment.
4. **Locking Screw:** 3mm set screw; used to lock vertically in place; up to 90 degrees of adjustment.
5. **Die Cast Socket Housing:** includes porcelain socket, 4KV rated G x 10TAL base, high temperature wire.
6. **Post:** made from aluminum d-bar; used to lock lamp cowl in place; tightens down with 3mm set screw.
7. **Lamp Cowl:** made of die cast aluminum; 2-7/8" in diameter. Allows the use of up to two (2) media accessories.
8. **Ballast Box:** made of extruded aluminum; 2-3/8" x 2-3/8" x 9-3/4".
9. **Ballast:** 20w electronic metal halide ballast. Input voltage...120V 60Hz, input current...0.35A. Power factor...0.99; \*FOR USE WITH 20W CERAMIC METAL HALIDE LAMPS ONLY.
10. **Compliances:** UL/C listed.

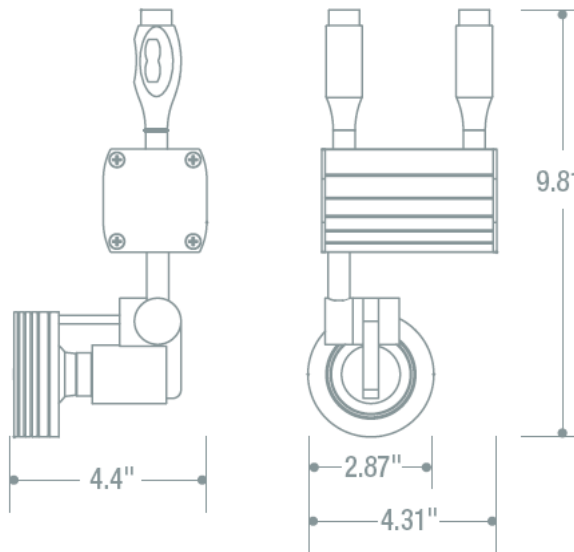

**Ordering Information**

Part Number	Lamp	Trim Style	Trim Finish
530.700	20W MR-16 Metal Halide	Spot	Satin Aluminum

Use with FleXsion Track System.  
Lamps Not Included

Ardee Lighting reserves the right to change product specifications without prior notification.

	<b>Ardee Lighting</b>	
5/23/2008	PO Box 1769 · 639 Washburn Switch Rd · Shelby · NC 28151 T 704. 482.2811 F 800.275.1544 E ardee@jjishelby.com www.ardeelighting.com	222276