



Specifications:

70W, PAR30 Metal Halide Spot with integral ballast for 120 volt flexible track system.

Features

1. **Threaded Coupling Cap:** made of die cast aluminum; locks coupler onto track.
2. **Hinged Extrusion Coupler:** made of die cast aluminum; connects fixture to track.
3. **Swivel:** 358 Degree rotation for horizontal adjustment.
4. **Locking Screw:** 3mm set screw; used to lock vertically in place; up to 90 degrees of adjustment.
5. **Die Cast Socket Housing:** includes porcelain socket, 4KV rated medium base, high temperature wire.
6. **Post:** made from aluminum d-bar; used to lock lamp cowl in place; tightens down with 3mm set screw.
7. **Lamp Cowl:** made of die cast aluminum; 4-3/4" in diameter. Allows the use of up to two (2) media accessories.
8. **Ballast Box:** made of extruded aluminum; 2-3/8" x 2-3/8" x 9-3/4".
9. **Ballast:** 70w electronic metal halide ballast. Input voltage...120V 60Hz, input current...0.35A. Power factor...0.99; *FOR USE WITH 20W CERAMIC METAL HALIDE LAMPS ONLY.
10. **Compliances:** UL/C listed.

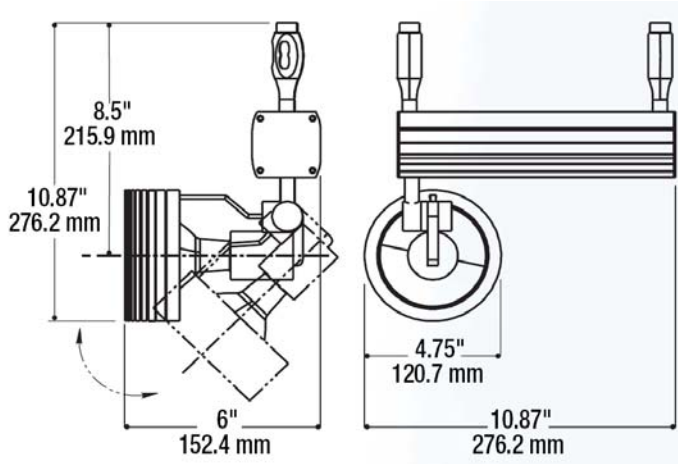

Ordering Information

Part Number	Lamp	Trim Style	Trim Finish
530.600	70W PAR30 Ceramic Metal Halide	SPOT	Satin Aluminum

Use with FleXsion Track System.
Lamps Not Included

Ardee Lighting reserves the right to change product specifications without prior notification.

	Ardee Lighting	
5/23/2008	PO Box 1769 · 639 Washburn Switch Rd · Shelby · NC 28151 T 704.482.2811 F 800.275.1544 E ardee@jjishelby.com www.ardeelighting.com	022146