

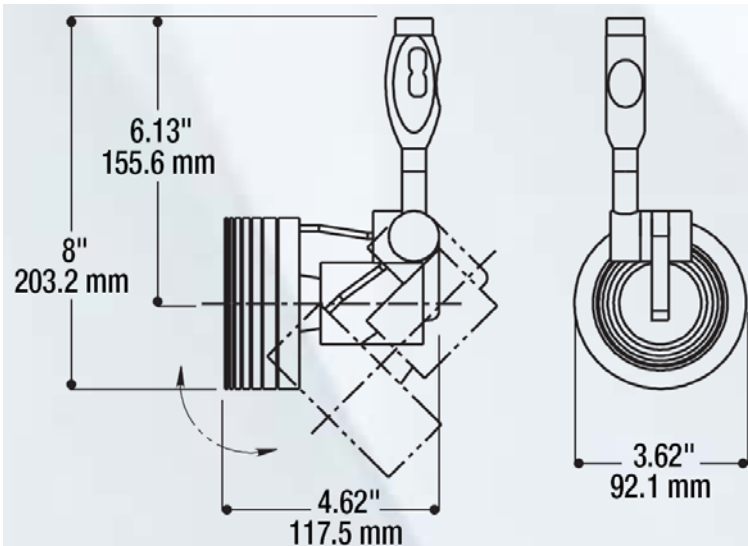

Specifications:
PAR20 Halogen SPOT for 120 volt flexible track system.

Features

1. **Threaded Coupling Cap:** made of die cast aluminum; locks coupler onto track.
2. **Hinged Extrusion Coupler:** made of die cast aluminum; connects fixture to track.
3. **Swivel:** 358 Degree rotation for horizontal adjustment.
4. **Locking Screw:** 3mm set screw; used to lock vertically in place; up to 90 degrees of adjustment.
5. **Die Cast Socket Housing:** includes porcelain socket, medium base, and high temperature wire.
6. **Post:** made from aluminum d-bar; used to lock lamp cowl in place; tightens down with 3mm set screw.
7. **Lamp Cowl:** made of die cast aluminum; 3-5/8" in diameter. Allows the use of up to two (2) media accessories.
8. **Compliances:** UL/C listed.



Ordering Information

Part Number	Lamp	Trim Style	Trim Finish
530.200	120V Halogen Medium Base PAR20, 50 watt	SPOT	Satin Aluminum

Use with FleXsion Track System
Lamps Not Included

	Ardee Lighting	
5/23/2008	PO Box 1769 · 639 Washburn Switch Rd · Shelby · NC 28151 T 704. 482.2811 F 800.275.1544 E ardee@jjishelby.com www.ardeelighting.com	022134



Flexsion

530.200

TYPE: _____

Ardee Lighting reserves the right to change product specifications without prior notification.

	Ardee Lighting	
5/23/2008	PO Box 1769 · 639 Washburn Switch Rd · Shelby · NC 28151 T 704.482.2811 F 800.275.1544 E ardee@jjishelby.com www.ardeelighting.com	022134