



Specifications:

MR16/PAR16 Halogen Spot for 120 volt flexible track system.

Features:

1. **Threaded Coupling Cap:** made of die cast aluminum; locks coupler onto track.
2. **Hinged Extrusion Coupler:** made of die cast aluminum; connects fixture to track.
3. **Swivel:** 358 Degree rotation for horizontal adjustment.
4. **Locking Screw:** 3mm set screw; used to lock vertically in place; up to 90 degrees of adjustment.
5. **Die Cast Socket Housing:** includes porcelain socket, GZ10 base (accepts GU10 base lamps), and high temperature wire.
6. **Post:** made from aluminum d-bar; used to lock lamp cowl in place; tightens down with 3mm set screw.
7. **Lamp Cowl:** made of die cast aluminum; 2-7/8" in diameter. Allows the use of up to two (2) media accessories.
8. **Compliances:** UL/C listed.

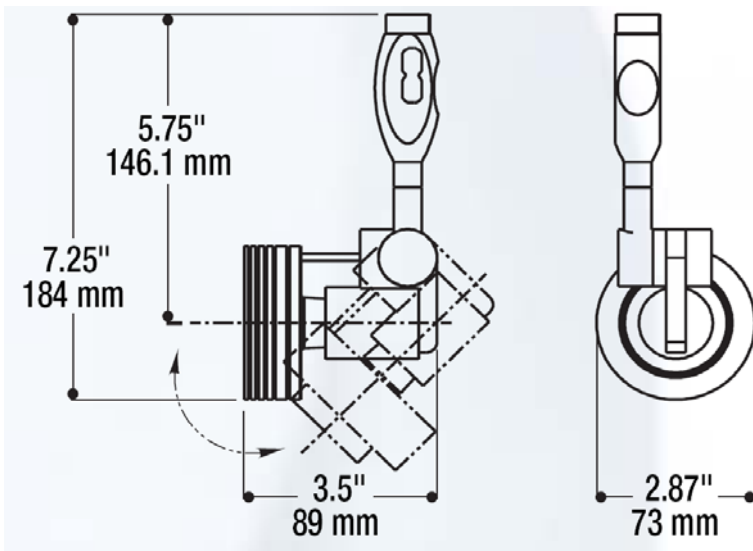

Ordering Information

Part Number	Lamp	Trim Style	Trim Finish
530.100	120V Halogen GU10 or GZ10 Base, 50 watt	SPOT	Satin Aluminum

Use with FleXsion Track System
Lamps Not Included

Ardee Lighting reserves the right to change product specifications without prior notification.

Ardee Lighting			
5/23/2008	PO Box 1769 · 639 Washburn Switch Rd · Shelby · NC 28151 T 704.482.2811 F 800.275.1544 E ardee@jjishelby.com www.ardeelighting.com		022129